

Exhaust System - V6 S/C 3.0L Petrol - Exhaust System

Description and Operation

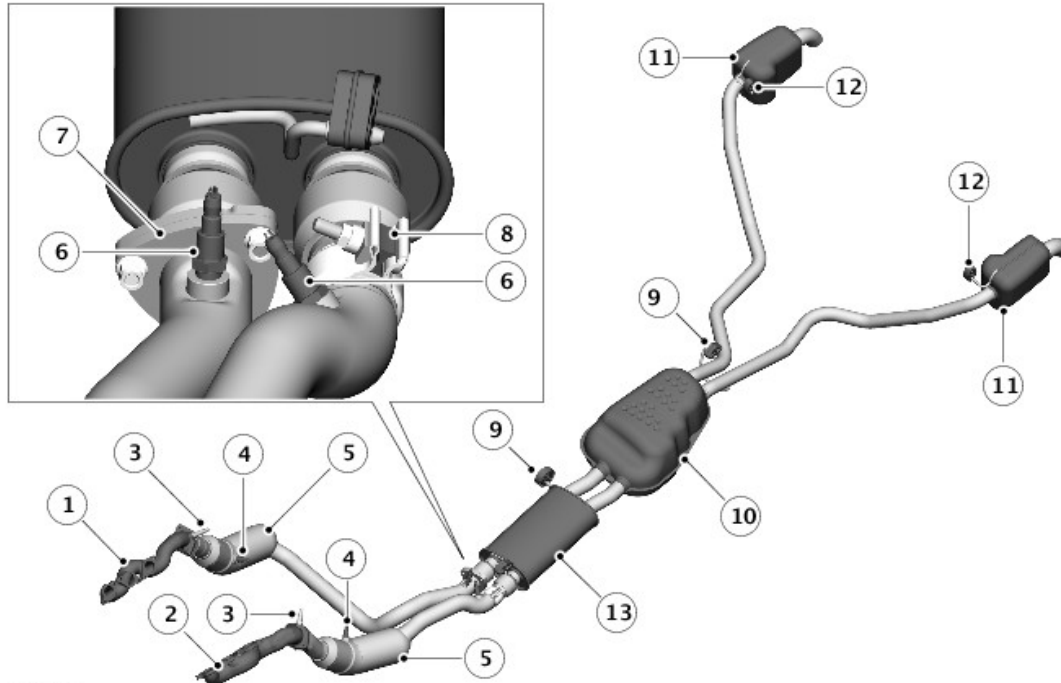

E160671

Item	Part Number	Description
1	-	Exhaust manifold - Bank 1
2	-	Exhaust manifold - Bank 2
3	-	Pre-catalyst Heated Oxygen Sensor (HO2S) sensors (2 off)
4	-	Mid-catalyst HO2S (2 off)
5	-	Catalytic converter
6	-	Post-catalyst HO2S (2 off) Rear Silencer
7	-	Flange joint - Front section to center section
8	-	Clamp Exhaust Valve
9	-	Mounting rubber
10	-	Silencer - center
11	-	Silencer - rear
12	-	Mounting rubber
13	-	Silencer - front.

OVERVIEW

The V6 3.0L SC (supercharged) petrol engine exhaust system is supplied as three separate assemblies; a left front section incorporating a catalytic converter, a right front section incorporating a catalytic converter and a rear section incorporating a front silencer, a centre silencer and two rear silencers.

The system is attached to the underside of the body with 5 mounting rubbers which are located on mild steel hanger bars that are welded to the system. The mounting rubbers locate on corresponding hangers which are welded to the underside of the vehicle body. The system is routed mainly on the inside of the left chassis longitudinal before splitting near the rear differential to exit at each side of the rear of the vehicle.

The system has service repair items available. Indentations in the rear section, between the center and the rear silencers, show the cut points for the service replacement rear silencers or front section. When a service repair section is used, the joint is connected using a sleeve and two clamps to connect the pipes at the cut points.

DESCRIPTION

Front Section

Both front sections have a loose flange with two holes which provide for the attachment with two bolts onto the left and right exhaust manifolds. The flange is sealed by a tapered seat in the flange and a machined cone on the manifold.

Each flange is located on a short, straight pipe, which in turn is welded to the body of the catalytic converter. The

pipe has a threaded boss which is welded over a hole to provide location for the mid - catalyst [HO2S \(heated oxygen sensor\)](#) in a position between the pre-catalyst and the main catalyst.

Both outlet pipes from the catalytic converters, have a threaded boss which provide location for the post-catalyst HO2S.

The mid and post catalyst HO2S monitor the exhaust gasses leaving the engine. The [ECM \(engine control module\)](#) uses this information to provide accurately metered quantities of fuel to the combustion chambers to ensure the most efficient use of fuel and to minimize the exhaust emissions.

The front section also has a mass damper which will absorb resonance from the system.

Rear Section

The rear section comprises of a front silencer, center silencer and two rear silencers.

The front silencer comprises a double skin and two end plates which are rolled together to give a capacity of 7.0 litres (427 in3). The silencer contains baffles and perforated tubes which reduce noise as the exhaust gasses pass through the silencer. A hanger bar is welded to the front of the silencer and provides for the location of a mounting rubber.

The centre silencer comprises two pressed stainless steel shells which are welded together to give a capacity of 25.2 litres (1538 in3). The silencer contains baffles and perforated tubes which reduce noise as the exhaust gasses pass through the silencer. A hanger bar is welded to the front right side of the silencer and provides location for a mounting rubber.

Each outlet pipe terminates in a welded joint with the tail silencers. The outlet pipes have a hanger bar which provides for the location of a mounting rubber.

A hanger bar is welded to the front face of each rear silencer and provides for the location of a mounting rubber. The silencer is a rectangular fabrication with a baffle tube which is surrounded with glass fibre to provide further noise suppression. Each silencer has a capacity of 4 litres (244 in3).

Each outlet pipe is curved downwards to direct exhaust gasses away from the rear of the vehicle.

Exhaust Manifolds

The cast exhaust manifolds are unique for each cylinder bank. Spacers on the securing bolts allow the manifolds to expand and retract with changes of temperature while maintaining the clamping loads. Heat shields are integrated into the exhaust manifold gaskets. Each manifold has a threaded port near to its outlet which allows for the fitment of the pre-catalyst [HO2S](#).

OPERATION

Catalytic Converters



In the catalytic converters, the exhaust gases are passed through honeycombed ceramic elements coated with a special surface treatment called 'washcoat'. The washcoat increases the surface area of the ceramic elements by a factor of approximately 7000°. On top of the washcoat is a coating containing palladium and rhodium, which are the active constituents for converting harmful emissions into inert by-products. The palladium and rhodium take oxygen from nitrogen oxides, to leave nitrogen, and combine the oxygen with carbon monoxide and hydrocarbons to leave carbon dioxide and water.

Exhaust System - V6 S/C 3.0L Petrol - Exhaust System Repair

General Procedures

Check

NOTES:

-  Some variation in the illustrations may occur, but the essential information is always correct.
-  Some components shown removed for clarity.

All vehicles

1.  **WARNING:** Do not work on or under a vehicle supported only by a jack. Always support the vehicle on safety stands.

Raise and support the vehicle.

2.

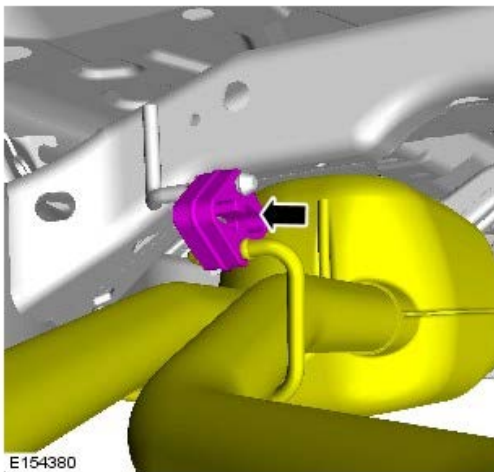

Vehicles with diesel engine

3.

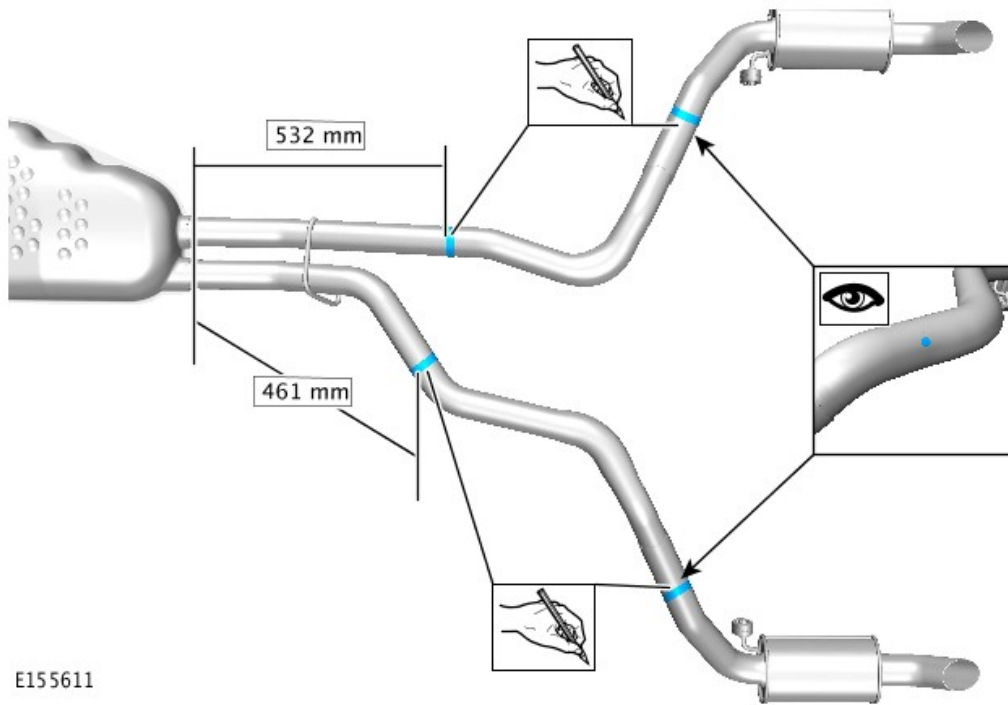

E155611

Vehicles with petrol engine
4.

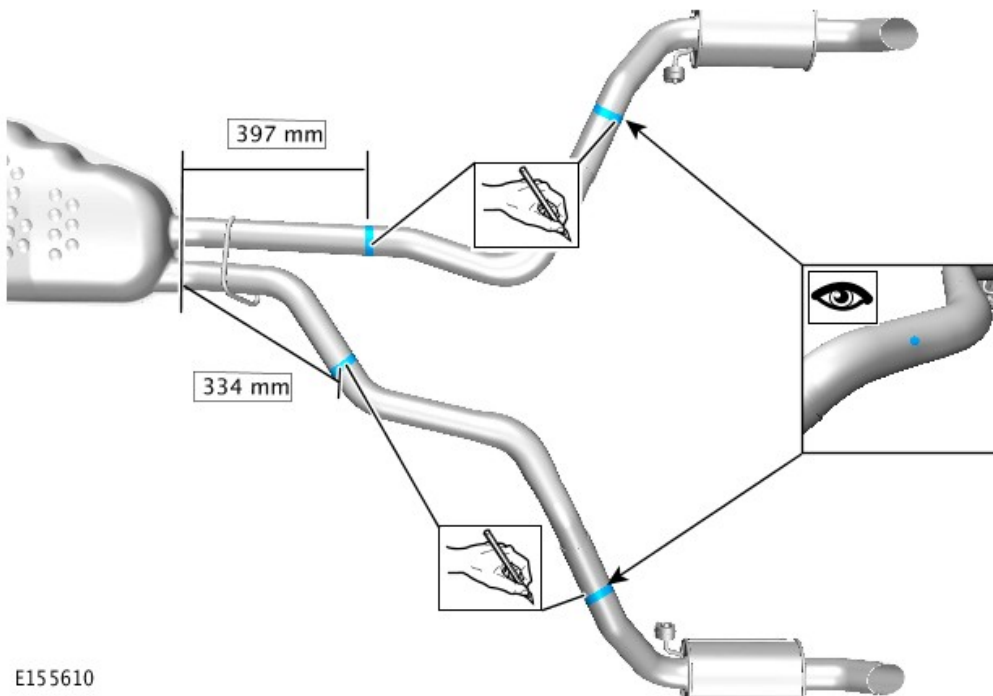

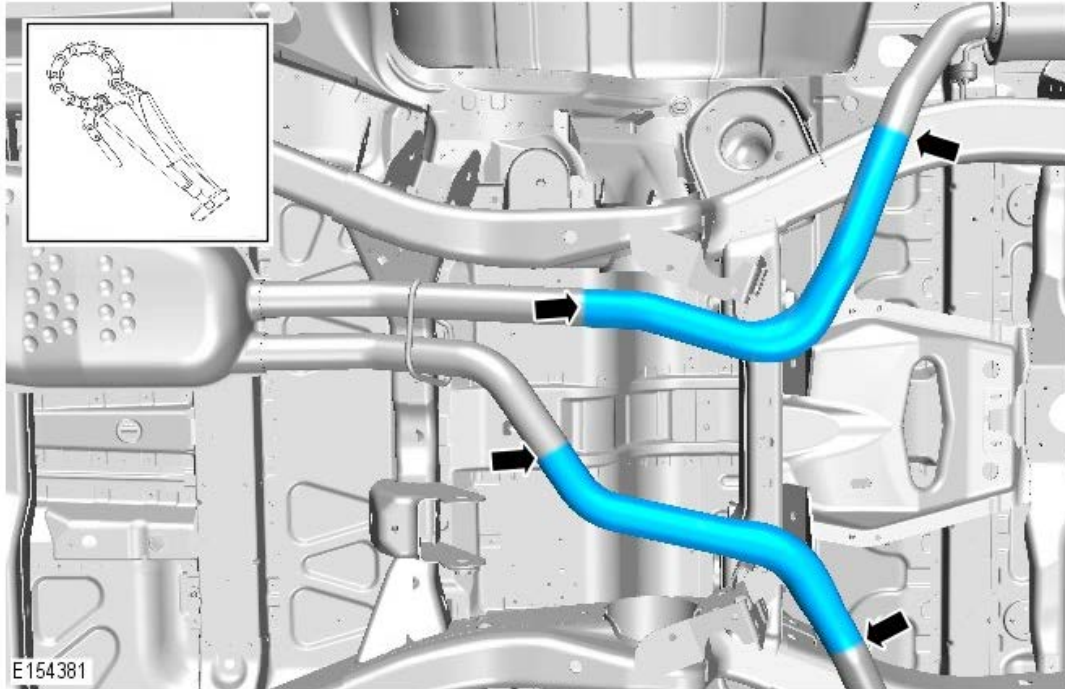

E155610

All vehicles
5.



Adjustment

NOTES:

-  Some variation in the illustrations may occur, but the essential information is always correct.
-  Some components shown removed for clarity.

1.

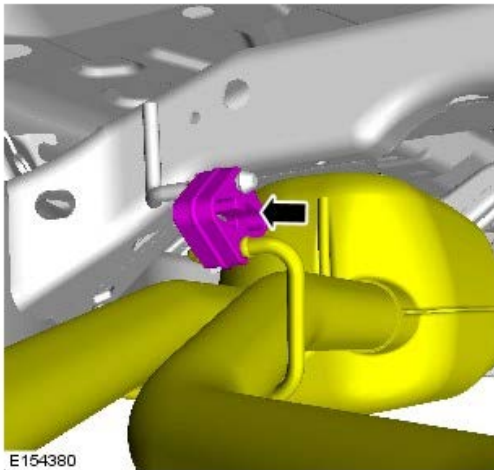

2. Torque: 55 Nm

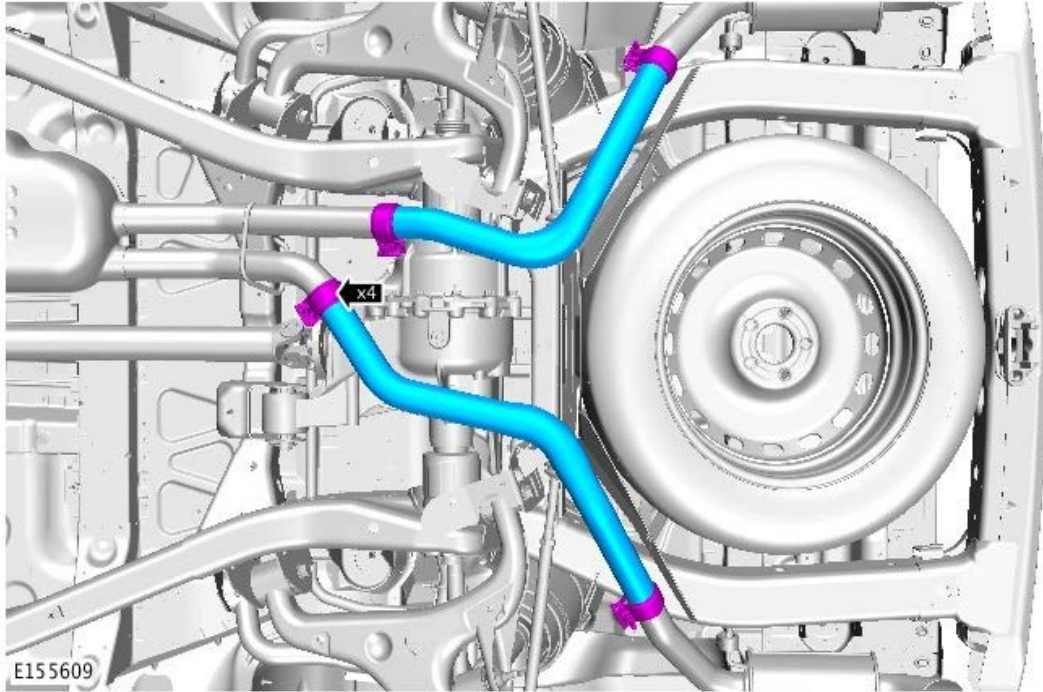

3. After the exhaust has been tightened, measure the clearance between exhaust and the chassis. If the measurement is not correct, loosen the exhaust retaining clamp and position the exhaust until the clearance is achieved.

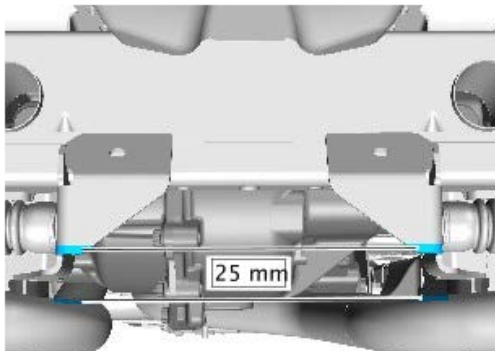

E155612

Exhaust System - V6 S/C 3.0L Petrol - Catalytic Converter LH

Removal and Installation

Special Tool(s)

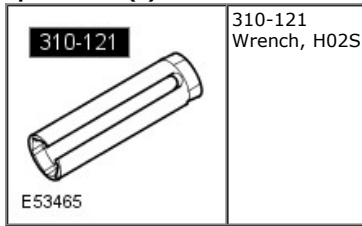

Removal



WARNING: Observe due care when working near a hot exhaust system.



NOTE: Removal steps in this procedure may contain installation details.

-  **WARNING:** Make sure to support the vehicle with axle stands.
Raise and support the vehicle.
- Refer to: [Exhaust System](#) (309-00B Exhaust System - V6 S/C 3.0L Petrol, Removal and Installation).
- Torque:** 55 Nm

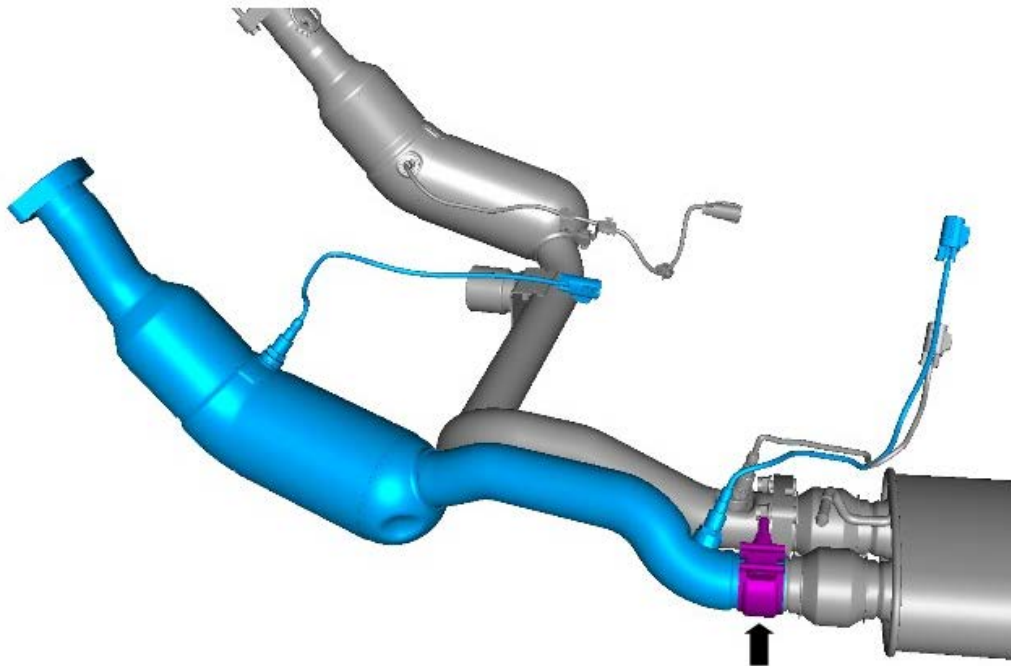

E160680

-  **NOTE:** Do not disassemble further if the component is removed for access only.



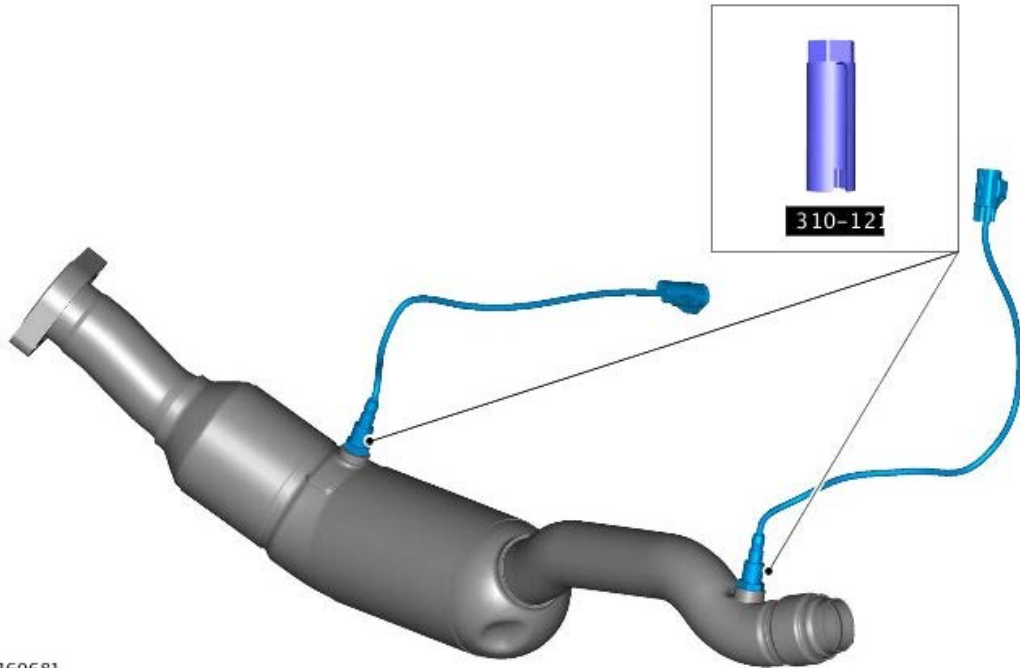

Special Tool(s): [310-121](#)
Torque: 48 Nm



E160681

Installation

1. CAUTIONS:

-  Make sure the anti-seize compound does not contact the heated oxygen sensor (HO2S) tip.
-  If accidentally dropped or knocked install a new sensor.
-  Make sure the HO2S wiring harness is not twisted more than 180 degrees and is not in contact with either the exhaust or driveshaft.
-  NOTE: If the original sensor is to be installed, apply lubricant meeting specification ESE-M12A4-A to the thread of the sensor.

To install, reverse the removal procedure.

Exhaust System - V6 S/C 3.0L Petrol - Catalytic Converter RH

Removal and Installation

Removal



WARNING: Observe due care when working near a hot exhaust system.



NOTE: Removal steps in this procedure may contain installation details.

1. Refer to: [Exhaust System](#) (309-00B Exhaust System - V6 S/C 3.0L Petrol, Removal and Installation).



2. **WARNING:** Make sure to support the vehicle with axle stands.

Raise and support the vehicle.

3. Torque: 55 Nm

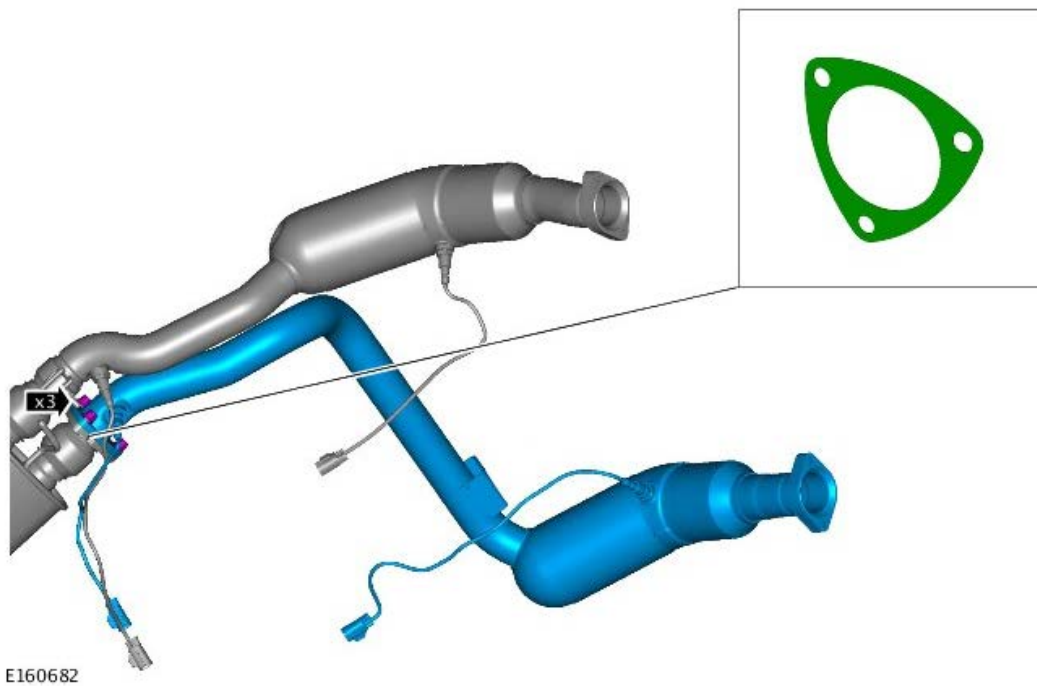

4. **NOTE:** Do not disassemble further if the component is removed for access only.



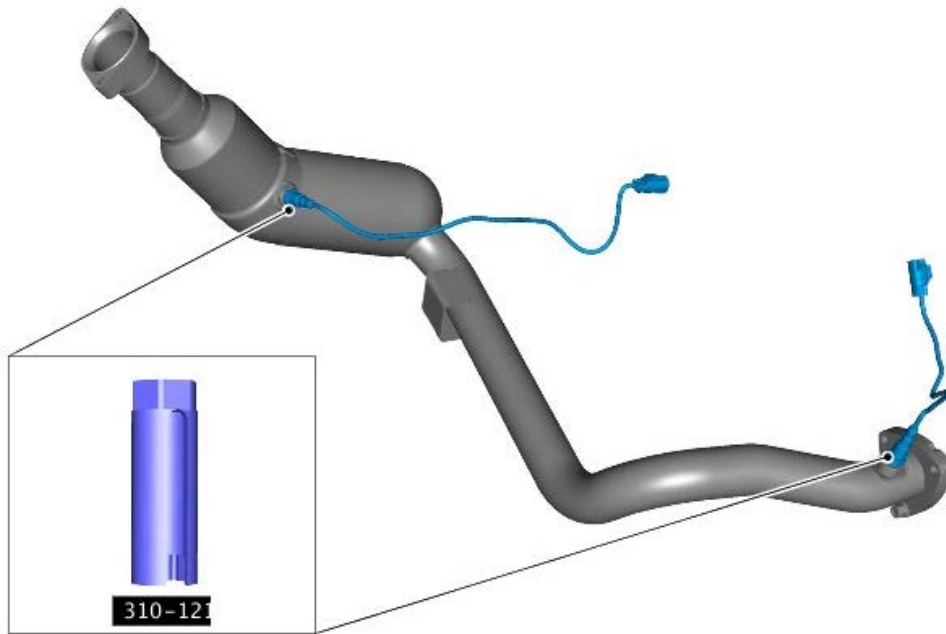

Torque: 48 Nm



E160684

Installation

1. CAUTIONS:

-  Make sure the anti-seize compound does not contact the heated oxygen sensor (HO2S) tip.
-  If accidentally dropped or knocked install a new sensor.
-  Make sure the HO2S wiring harness is not twisted more than 180 degrees and is not in contact with either the exhaust or driveshaft.
-  NOTE: If the original sensor is to be installed, apply lubricant meeting specification ESE-M12A4-A to the thread of the sensor.

To install, reverse the removal procedure.

Exhaust System - V6 S/C 3.0L Petrol - Exhaust System

Removal and Installation

Removal

 **WARNING:** Observe due care when working near a hot exhaust system.

 **NOTE:** Removal steps in this procedure may contain installation details.

1.  **WARNING:** Make sure to support the vehicle with axle stands.

Raise and support the vehicle.

2. Refer to: [Engine Undershield](#) (501-02 Front End Body Panels, Removal and Installation).
3. Refer to: [Transmission Support Crossmember - V6 S/C 3.0L Petrol](#) (502-02 Full Frame and Body Mounting, Removal and Installation).

4.

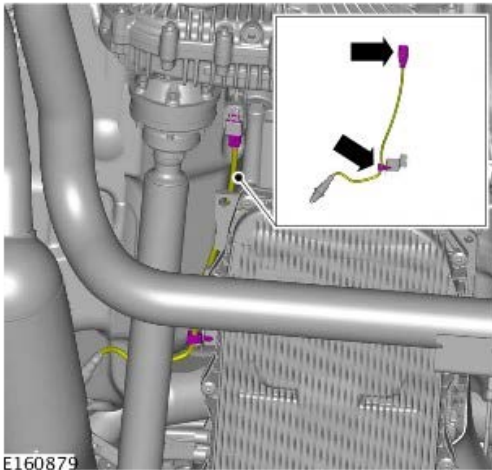

5.

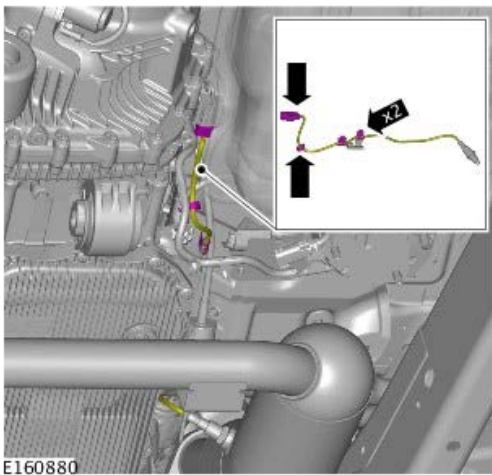

6.  **CAUTION:** Make sure that the exhaust system is supported with suitable retaining straps.

 **NOTE:** The step must be carried out on both sides.

Torque: 40 Nm

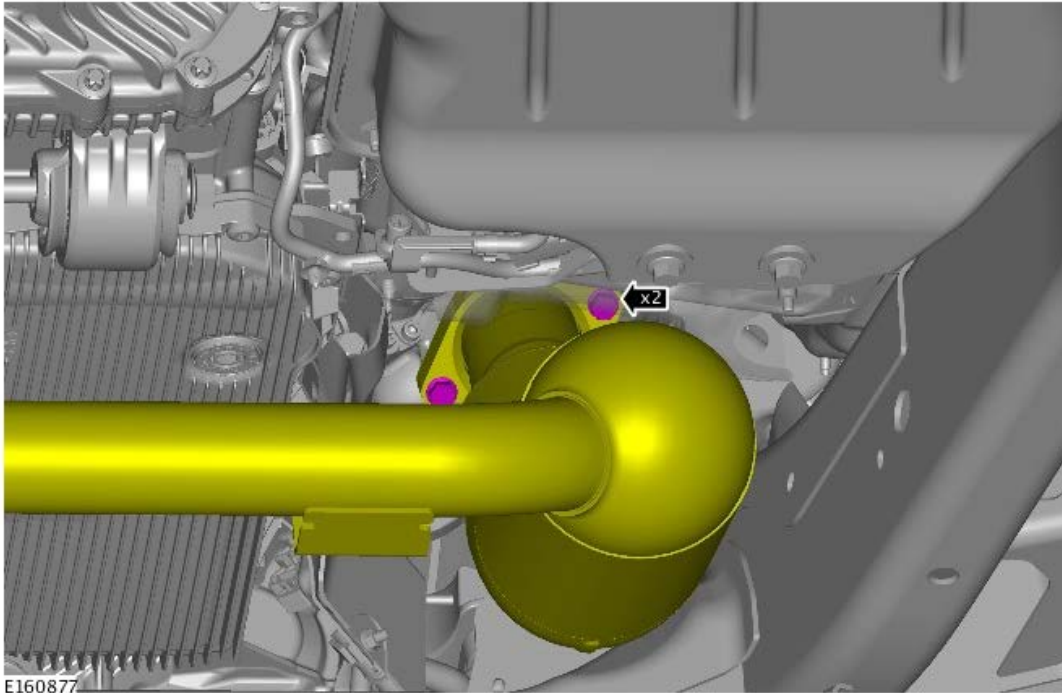

7.  CAUTION: Make sure that the exhaust system is supported with suitable retaining straps.

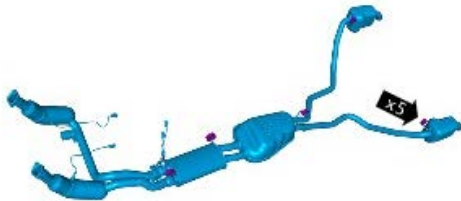
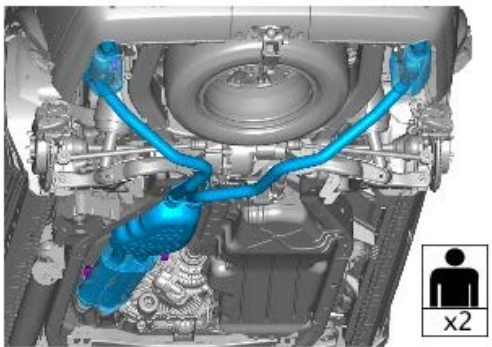

8.  NOTE: Do not disassemble further if the component is removed for access only.

Torque: 48 Nm

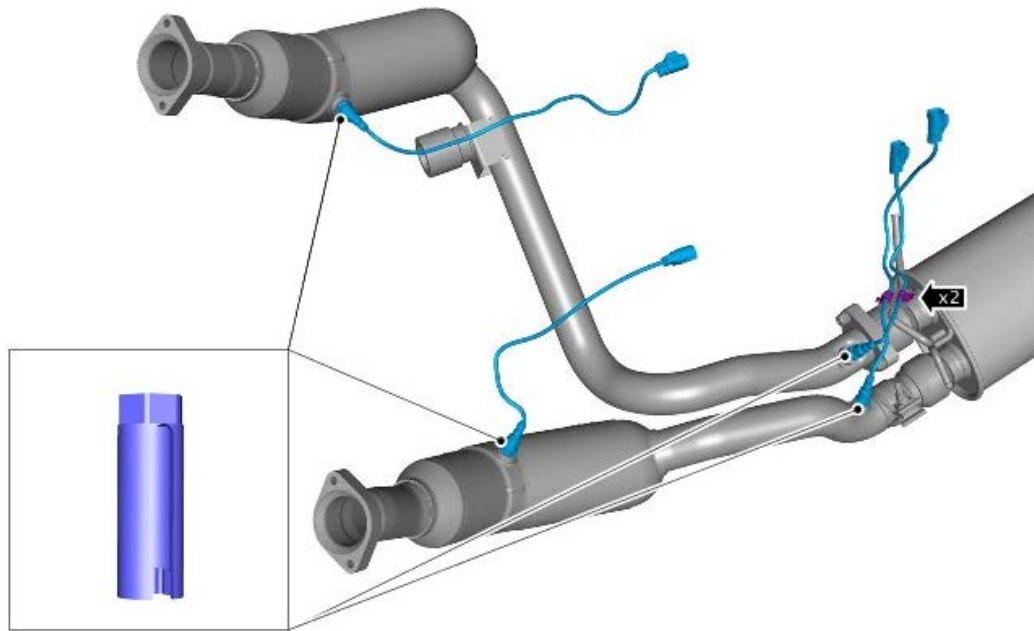

E160881

Installation

1. To install, reverse the removal procedure.

Exhaust System - V6 S/C 3.0L Petrol - Front Muffler

Removal and Installation

Special Tool(s)

 E130266	100-051 Cutter, Exhaust Pipe
--	---------------------------------

Removal



WARNING: Observe due care when working near a hot exhaust system.



NOTE: Removal steps in this procedure may contain installation details.

1. Refer to: [Engine Undershield](#) (501-02 Front End Body Panels, Removal and Installation).



2. **WARNING:** Make sure to support the vehicle with axle stands.

Raise and support the vehicle.

3. Torque: 55 Nm

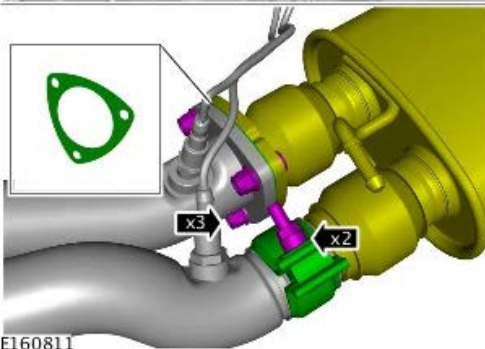
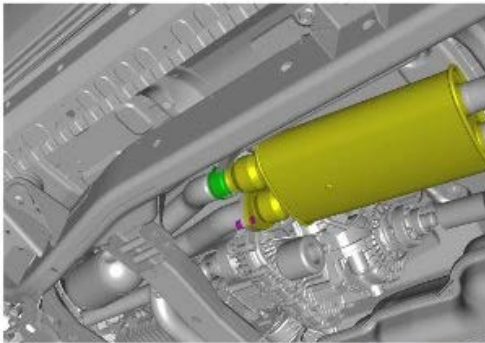

4. **CAUTION:** Make sure that the exhaust system is supported with suitable retaining straps.



NOTE: The step must be carried out on both sides.

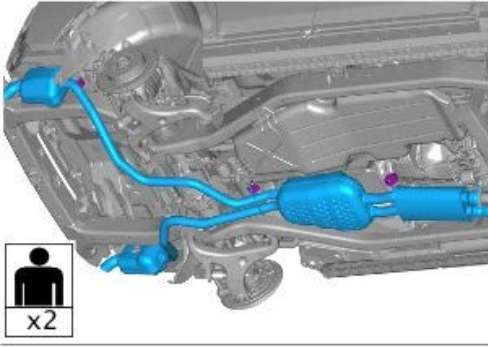

E160809

5.  NOTE: Do not disassemble further if the component is removed for access only.
 - Special Tool(s): [100-051](#)

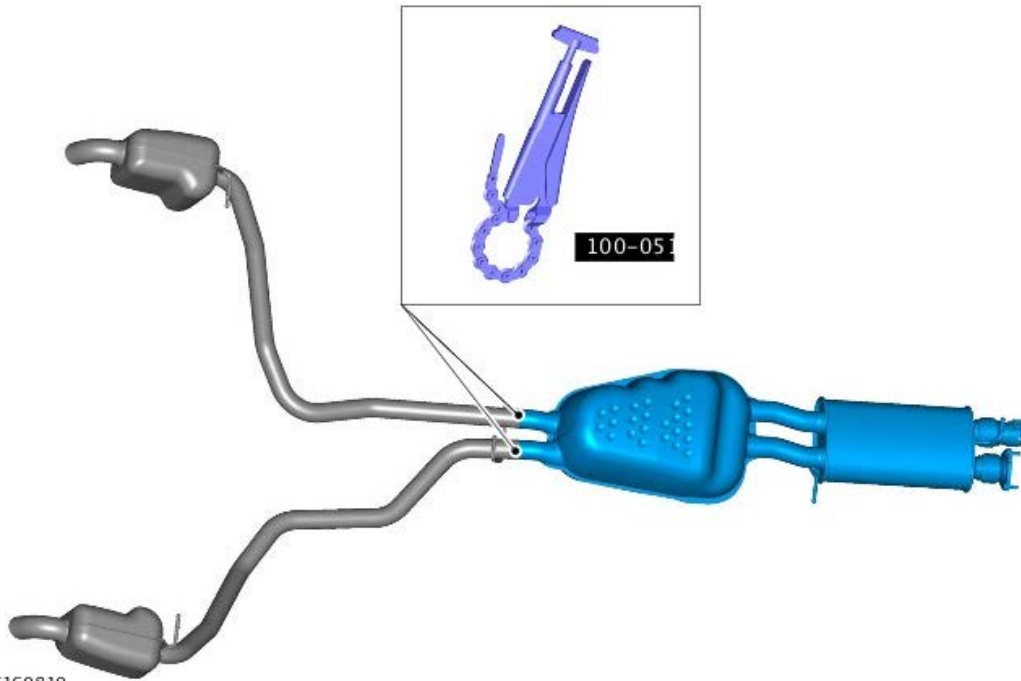

E160810

Installation

1.  WARNING: Make sure that any corrosion or dirt is removed from the mating surfaces.

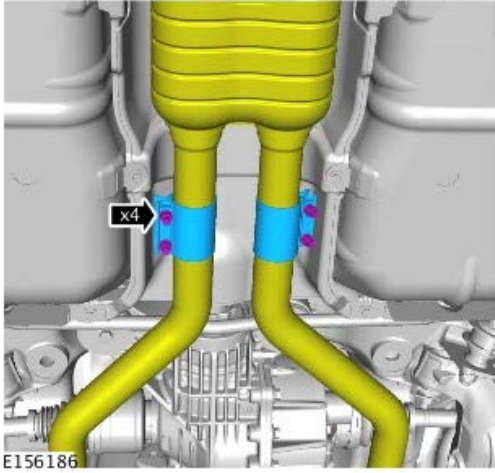

To install, reverse the removal procedure.

Exhaust System - V6 S/C 3.0L Petrol - Rear Muffler

Removal and Installation

Removal

 **WARNING:** Observe due care when working near a hot exhaust system.

NOTES:

 Removal steps in this procedure may contain installation details.

 LH illustration shown, RH is similar.

1.  **WARNING:** Make sure to support the vehicle with axle stands.

Raise and support the vehicle.

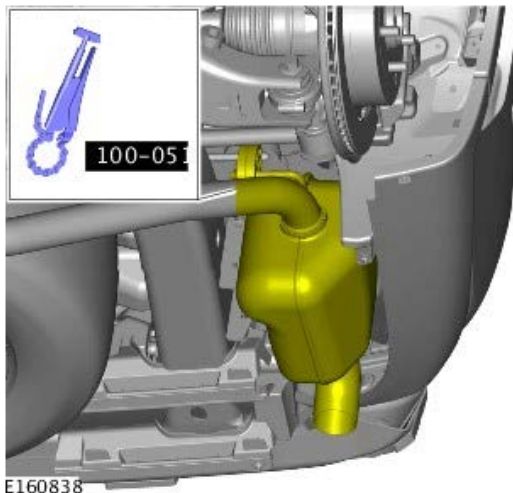

E160838

2.  **CAUTION:** Make sure that the exhaust system is supported with suitable retaining straps.

 **NOTE:** Using the special tool, cut the exhaust pipe at the marked position.

3.

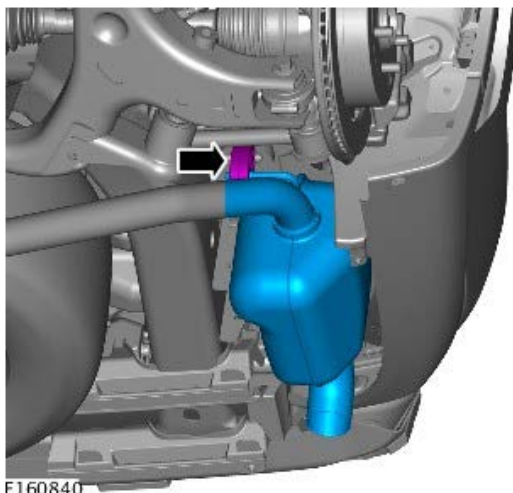

E160840

Installation

1.  **WARNING:** Make sure that any corrosion

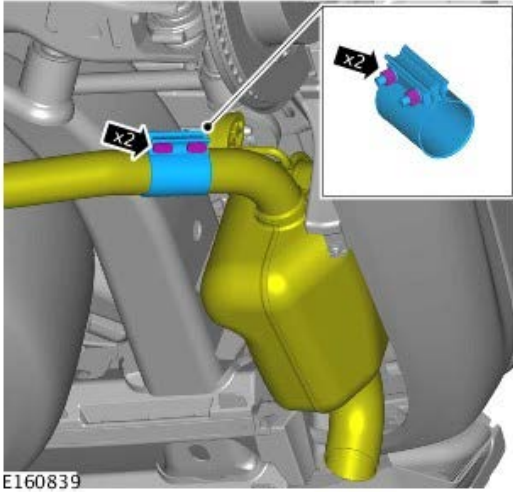

E160839

or dirt is removed from the mating surfaces.
To install, reverse the removal procedure.